



BULLETIN

- CONCEALED-HEAD
- SELF-CLINCHING
- STUDS &
- STANDOFFS



CH 1205
Revised 406

PEM[®] CONCEALED-HEAD STUDS* AND STANDOFFS

These studs and standoffs ensure permanent mounting in metal sheets as thin as .062 in. / 1.6 mm.

The fastener head is locked securely in a blind, milled hole and is able to handle substantial loads. The concealed-head feature allows the side of the sheet opposite installation to remain smooth.

Sheet preparation only requires a milled blind hole to the recommended minimum depth. Center-cutting end mills for hole preparation are available from PennEngineering. Installation of the concealed-head studs and standoffs is simple using a hollow punch and solid anvil. Place the head of the fastener in the hole and insert using any standard press. Displaced sheet metal flows smoothly around the head into the undercut.

** Some PEM[®] self-clinching concealed-head studs meet NASM63540 specifications. For a complete Military Specification and National Aerospace Standards Reference Guide (Bulletin NASM) consult our Marketing Department or check our web site.*



Part Number Designation

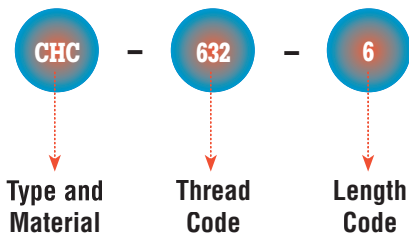

Concealed-head Stud



Concealed-head Standoff

ALUMINUM AND STAINLESS STEEL STUDS TYPES CHA, CFHA, CHC, CFHC

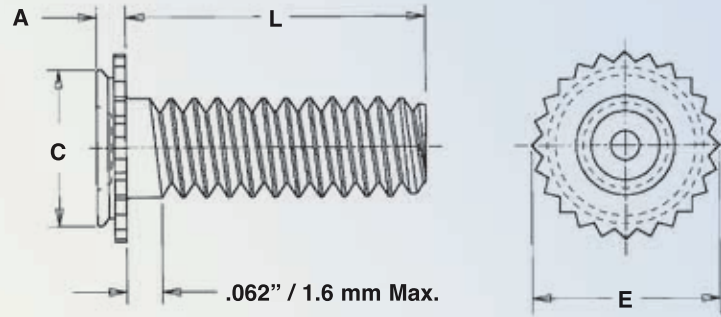

All dimensions are in inches.

UNIFIED	Thread Size (#4-40)	Type		Thread Code	Length Code "L" ±.015 (Length code is in 16ths of an inch)						Min. Sheet Thickness	Blind Mounting Hole Dia. +.003 - .000	Min. Depth of Blind Hole (1)	A Max.	E ±.010	C Max.	Min. Dist. Hole C/L To Edge	Max. Hole In Attached Parts
		Fastener Material			.250	.375	.500	.625	.750	1.00								
		Aluminum	Stainless Steel															
	.112-40 (#4-40)	CHA ^{NS}	CHC	440	4	6	8	10 ^{NS}	12 ^{NS}	NA	.062 .093	.172	.043 .075	.043 .075	.205	.171	.156	.135
		CFHA	CFHC															
	.138-32 (#6-32)	CHA ^{NS}	CHC	632	4	6	8	10	12	16	.062 .093	.213	.043 .075	.043 .075	.250	.212	.188	.160
		CFHA	CFHC															
	.164-32 (#8-32)	CHA ^{NS}	CHC	832	4	6	8	10	12	16	.062 .093	.290	.043 .075	.043 .075	.328	.289	.219	.185
		CFHA ^{NS}	CFHC															
	.190-32 (#10-32)	CHA ^{NS}	CHC ^{NS}	032	NA	6 ^{NS}	8	10	12	16	.062 .093	.312	.043 .075	.043 .075	.350	.311	.250	.210
		CFHA ^{NS}	CFHC															

All dimensions are in millimeters.

METRIC	Thread Size x Pitch	Type		Thread Code	Length Code "L" ±0.4 (Length code is in millimeters)							Min. Sheet Thickness	Blind Mounting Hole Dia. +0.08	Min. Depth of Blind Hole (1)	A Max.	E ±0.25	C Max.	Min. Dist. Hole C/L To Edge	Max. Hole In Attached Parts
		Fastener Material			6	8	10	12	16	20	NA								
		Aluminum	Stainless Steel																
	M3 X 0.5	CHA ^{NS}	CHC	M3	6	8	10	12	16	20	NA	1.6 2.4	4.37	1.1 1.91	1.1 1.91	5.21	4.35	4	3.6
		CFHA	CFHC																
	M4 X 0.7	CHA ^{NS}	CHC	M4	6	8	10	12	16	20	25	1.6 2.4	7.37	1.1 1.91	1.1 1.91	8.33	7.35	5.6	4.6
		CFHA	CFHC																
	M5 X 0.8	CHA	CHC	M5 ^{NS}	NA	NA	10	12	16	20	25	1.6 2.4	7.93	1.1 1.91	1.1 1.91	8.89	7.9	6.4	5.6
		CFHA	CFHC																

(1) Blind holes may be deeper than minimums except where sheet material is at or near minimum thickness.

Fasteners should always be installed so the flange is flush with the surface of the sheet.

NS Not stocked. Available on special order.

NA Not available.

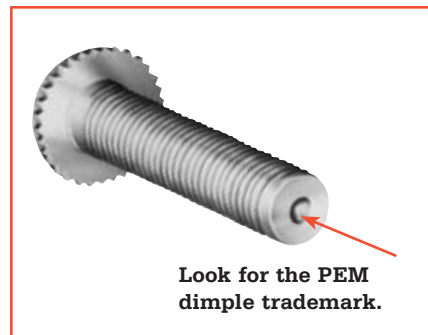

STAINLESS STEEL STANDOFFS TYPES CSS, CSOS

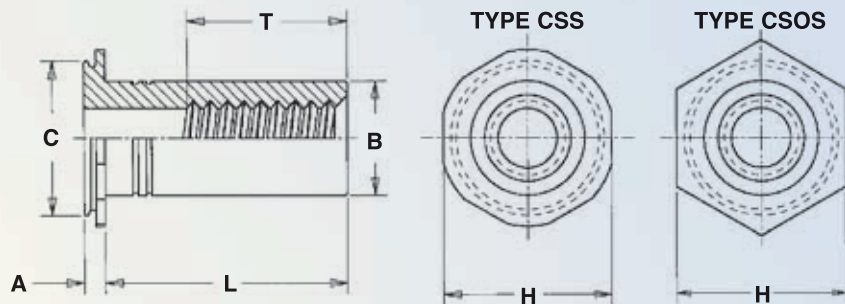

All dimensions are in inches.

UNIFIED	Thread Size	Type	Thread Code	Length Code "L" (Length code is in 16ths of an inch) +.002 - .005							Min. Sheet Thickness	Blind Mounting Hole Dia. +.003 -.000	Min. Depth of Blind Hole (1)	Min. Depth Full Thread T (2)	A Max.	B Max. (4)	C Max.	H Nom.	Min. Dist. Hole C/L To Edge	
		Fastener Material		.187	.250	.312	.375	.500	.625	.750										1.00
		Stainless Steel																		
.112-40 (#4-40)	CSS	440	3 ⁽²⁾	4	5	6	8 ⁽³⁾	10 ^{NS} ₍₃₎	12 ^{NS} ₍₃₎	16 ^{NS} ₍₃₎	.062	.213	.043	.188	.043	.165	.212	.250	.188	
	CSOS										.093		.075		.075					
.138-32 (#6-32)	CSS	632	3 ⁽²⁾	4 ⁽²⁾	5	6	8 ⁽³⁾	10 ⁽³⁾	12 ⁽³⁾	16 ^{NS} ₍₃₎	.062	.290	.043	.250	.043	.213	.289	.312	.219	
	CSOS										.093		.075		.075					
.164-32 (#8-32)	CSS	832 ^{NS}	3 ⁽²⁾	4 ⁽²⁾	5	6	8 ⁽³⁾	10 ⁽³⁾	12 ⁽³⁾	16 ⁽³⁾	.062	.312	.043	.250	.043	.245	.311	.344	.250	
	CSOS										.093		.075		.075					
.190-32 (#10-32)	CSS	032 ^{NS}	3 ⁽²⁾	4 ⁽²⁾	5 ⁽²⁾	6 ⁽²⁾	8	10 ⁽³⁾	12 ⁽³⁾	16 ⁽³⁾	.062	.344	.043	.375	.043	.290	.343	.375	.281	
	CSOS										.093		.075		.075					
.250-20 (1/4-20)	CSS	0420 ^{NS}	3 ⁽²⁾	4 ⁽²⁾	5 ⁽²⁾	6 ⁽²⁾	8	10	12 ⁽³⁾	16 ⁽³⁾	.062	.390	.043	.375	.043	.354	.389	.438	.375	
	CSOS										.093		.075		.075					

All dimensions are in millimeters.

METRIC	Thread Size x Pitch	Type	Thread Code	Length Code "L" (Length code is in millimeters) +0.05 - 0.13										Min. Sheet Thickness	Blind Mounting Hole Diameter +0.08	Min. Depth of Blind Hole (1)	Min. Depth Full Thread T (2)	A Max.	B Max. (4)	C Max.	H Nom.	Min. Dist. Hole C/L To Edge							
		Fastener Material		4 ⁽²⁾	6 ⁽²⁾	8 ⁽⁵⁾	10 ⁽³⁾	12 ^{NS} ₍₃₎	16 ^{NS} ₍₃₎	20 ^{NS} ₍₃₎	25 ^{NS} ₍₃₎	1.6	5.41										1.1	5	1.1	4.2	5.39	6.35	4.8
		Stainless Steel																											
M3 X 0.5	CSS	M3	4 ⁽²⁾	6 ⁽²⁾	8 ⁽⁵⁾	10 ⁽³⁾	12 ^{NS} ₍₃₎	16 ^{NS} ₍₃₎	20 ^{NS} ₍₃₎	25 ^{NS} ₍₃₎	1.6	5.41	1.1	5	1.1	4.2	5.39	6.35	4.8										
	CSOS										2.4		1.91		1.91														
M4 X 0.7	CSS	M4	4 ^{NS} ₍₂₎	6 ⁽²⁾	8	10 ⁽⁵⁾	12 ⁽³⁾	16 ⁽³⁾	20 ^{NS} ₍₃₎	25 ^{NS} ₍₃₎	1.6	7.92	1.1	6.5	1.1	6.23	7.9	8.74	6.4										
	CSOS										2.4		1.91		1.91														
M5 X 0.8	CSS	M5 ^{NS}	4 ⁽²⁾	6 ⁽²⁾	8 ⁽²⁾	10	12	16 ⁽³⁾	20 ⁽³⁾	25 ⁽³⁾	1.6	8.74	1.1	9.6	1.1	7.37	8.72	9.53	7.2										
	CSOS										2.4		1.91		1.91														
M6 X 1	CSOS	M6 ^{NS}	4 ⁽²⁾	6 ⁽²⁾	8 ⁽²⁾	10	12	16 ⁽³⁾	20 ⁽³⁾	25 ⁽³⁾	2.4	9.9	1.91	9.6	1.91	9	9.89	11.11	9.5										

- (1) Blind mounting holes may be deeper than minimums except where sheet material is at or near minimum thickness. Fasteners should always be installed so the flange is flush with the surface of the sheet.
 - (2) For shorter standoff lengths, when "L" is less than "T", minimum thread depth will be equal to "L". Screws with lengths exceeding "L" should not be used for they may cause "jacking-out" of standoff from the sheet.
 - (3) Type CSS and CSOS are blind at hex end.
 - (4) If standoff is used as a bushing, the hole in attached part must not exceed "B" plus .020" / 0.51 mm.
 - (5) Type CSOS is blind at hex end.
- NS Not stocked. Available on special order.

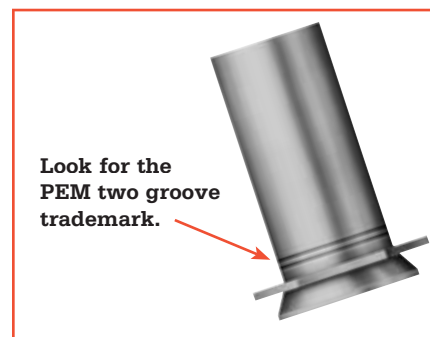

PERFORMANCE DATA⁽¹⁾

Type	Thread Code	Max. Tightening Torque (in. lbs.)	Test Sheet Material			
			Cold-rolled Steel		5052-H34 Aluminum	
			Installation (lbs.)	Pullout (lbs.)	Installation (lbs.)	Pullout (lbs.)
Concealed-head Standoffs						
CSS	440	4.75	4,000	300	2,800	200
	632	8.75	4,500	350	3,000	240
	832	18	4,800	400	4,000	270
	032	32	5,500	450	5,000	290
CSOS	440	3.8	4,300	330	2,900	220
	632	7	5,000	360	3,200	240
	832	14.4	5,300	440	4,000	300
	032	25.6	6,000	600	5,000	400
	0420	64	6,500	650	5,500	430
Concealed-head Studs						
CHC	440	4.75	1,800	240	1,400	130
	632	9	2,500	260	1,800	160
	832	18	4,000	270	2,800	180
	032	32	5,000	290	4,000	210
CFHC	440	4.75	2,000	240	1,500	200
	632	9	2,700	350	2,500	260
	832	18	3,300	440	3,000	310
	032	32	4,000	680	3,500	360
CHA	440	2.85	(2)	(2)	1,400	125
	632	5.4	(2)	(2)	1,800	135
	832	10.8	(2)	(2)	2,800	145
	032	19.2	(2)	(2)	4,000	170
CFHA	440	2.85	(2)	(2)	1,500	190
	632	5.4	(2)	(2)	2,500	220
	832	10.8	(2)	(2)	3,000	240
	032	19.2	(2)	(2)	3,500	300

Type	Thread Code	Max. Tightening Torque (N•m)	Test Sheet Material			
			Cold-rolled steel		5052-H34 Aluminum	
			Installation (kN)	Pullout (N)	Installation (kN)	Pullout (N)
Concealed-head Standoffs						
CSS	M3	.55	17.8	1330	12.5	890
	M4	2	21.3	1775	17.8	1200
	M5	3.6	24.5	2000	22.2	1290
CSOS	M3	.44	19.2	1465	12.9	975
	M4	1.6	23.6	1955	17.8	1335
	M5	2.9	26.7	2665	22.2	1775
	M6	7.2	28.9	2860	24.4	1915
Concealed-head Studs						
CHC	M3	0.5	8	1065	6.2	575
	M4	2	17.8	1200	12.5	800
	M5	3.6	22.2	1290	17.8	930
CFHC	M3	0.5	8.9	1065	6.7	890
	M4	2	14.7	1955	13.3	1375
	M5	3.6	17.8	3020	15.6	1600
CHA	M3	0.3	(2)	(2)	6.2	555
	M4	1.2	(2)	(2)	12.5	645
	M5	2.16	(2)	(2)	17.8	755
CFHA	M3	0.3	(2)	(2)	6.7	845
	M4	1.2	(2)	(2)	13.3	1065
	M5	2.16	(2)	(2)	15.6	1330

- (1) The installation and pullout values reported are averages when all installation specifications and procedures are followed. Variations in mounting hole size, sheet material and installation procedure will affect this data. Performance testing of this product in your application is recommended. We will be happy to provide samples for this purpose.
- (2) Not applicable.

MATERIAL & FINISH SPECIFICATIONS

Type	Threads		Fastener Materials		Finish		For Use In Sheet Hardness	
	External ANSI B1.1 2A / ANSI / ASME B1.13M, 6g	Internal, ANSI B1.1 2B / ANSI / ASME B1.13M, 6H	2024-T4 Aluminum	300 Series Stainless Steel	No Finish	Passivated and/or tested per ASTM A380	70 or Less on the Rockwell "B" Scale	50 or Less on the Rockwell "B" Scale
CHA	•		•		•			•
CFHA	•		•		•			•
CHC	•			•		•		
CFHC	•			•		•		
CSS		•		•		•		•
CSOS		•		•		•		•

INSTALLATION

1. Mill a blind hole to the correct minimum depth.*
2. Place fastener into anvil hole.
3. Place the sheet over the shank of the fastener.
4. With punch and anvil surfaces parallel, apply squeezing force until flange is flush with mounting sheet.

*End mills available from PennEngineering. See chart below.

Types CFHA, CFHC, CHC, CHA
Concealed-head studs

Types CSOS, CSS
Concealed-head standoffs

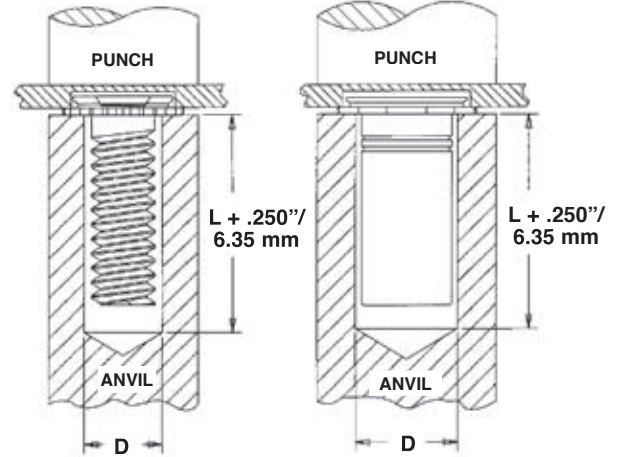

ANVIL "D" DIMENSIONS

All dimensions are in inches. (+.003 -.000)

Type	Thread Code				
	440	632	832	032	0420
CHA CHC	.127	.152	.179	.205	-
CFHA CFHC	.127	.152	.179	.205	-
CSS CSOS	.170	.218	.250	.295	.358

All dimensions are in millimeters. (+0.08)

Type	Thread Code			
	M3	M4	M5	M6
CHA CHC	3.4	4.4	5.4	-
CFHA CFHC	3.4	4.4	5.4	-
CSS CSOS	4.33	6.36	7.5	9.13

END MILL DESIGNATIONS

Double-ended, two-flute H.S.S. center-cutting end mills are available from stock.

PennEngineering does not manufacture center-cutting end mills, but we do keep a supply in stock for your convenience.

Thread Code	Fastener Type	Required Size End Mill	PEM Part No.
440, M3	CFHC, CHC, CFHA, CHA Studs	.172"	CHM-172
	CSOS, CSS Standoffs	.213"	CHM-213
632	CFHC, CHC, CFHA, CHA Studs	.213"	CHM-213
	CSOS, CSS Standoffs	.290"	CHM-290
832, M4	CFHC, CHC, CFHA, CHA Studs	.290"	CHM-290
	CSOS, CSS Standoffs	.312"	CHM-312
032, M5	CFHC, CHC, CFHA, CHA Studs	.312"	CHM-312
	CSOS, CSS Standoffs	.344"	CHM-344
0420, M6	CSOS Standoffs	.390"	CHM-390

RoHS compliance information can be found on our website.

Specifications subject to change without notice.
Check our website for the most current version of this bulletin.

PennEngineering®



North America: Danboro, PA 18916 USA • E-mail: info@pemnet.com • Tel: +1-215-766-8853 • Fax: +1-215-766-0143 • 800-237-4736 (USA Only)

U.K. And Europe: Doncaster, England • E-mail: uk@pemnet.com Tel: +44 (0)1302 765700 • Fax: +44 (0)1302 367580

Asia/Pacific: Singapore • E-mail: singapore@pemnet.com • Tel: +65-6-745-0660 • Fax: +65-6-745-2400

Shanghai, China • E-mail: china@pemnet.com • Tel: +86-21-5868-3688 • Fax: +86-21-5868-3988

Visit our PEMNET™ Resource Center at www.pemnet.com

CAGE-46384