



**KEYHOLE®**

**SELF-CLINCHING**

**STANDOFFS**

# BULLETIN



**SK** 605

Revised 406

# KEYHOLE<sup>®</sup> SELF-CLINCHING STANDOFFS

The PEM KEYHOLE<sup>®</sup> Standoff (Type SKC<sup>™</sup>) is designed so that a PC board or panel can be quickly slipped into place and then removed from an assembly by simply sliding the board sideways and lifting it off. PEM Keyhole standoffs can save valuable time and dramatically reduce the amount of loose hardware required.

These standoffs can be used for spacing or hanging of replaceable components.

Typically, several KEYHOLE standoffs are used with one standard PEM threaded standoff which accepts a screw to secure the board or component against any unwanted movement.



Look for the  
PEM "dimple"  
trademark.



## Part Number Designation



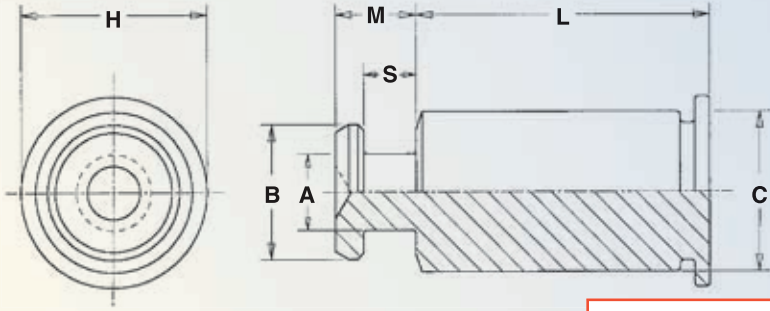

**FASTENER MATERIAL:**  
300 Series Stainless Steel

**FINISH:**  
Passivated and/or tested per ASTM A380

All dimensions are in inches.

UNIFIED	Type	Body Size - Sheet Code	Length "L" ± .005 (Length Code in 32nds of an inch)											A	B	C	S	M	H	D
	Stainless Steel		.188	.250	.312	.375	.437	.500	.562	.625	.750	.875	1.00	± .003	± .003	Max.	± .003	Max.	Nom	Anvil Hole + .003 - .000
SKC	6060	6	8	10	12	14	16	18	20	24	28	32	.099	.177	.212	.068	.108	.250	.216	

All dimensions are in millimeters.

METRIC	Type	Body Size - Sheet Code	Length "L" ± 0.13 (Length Code in millimeters)											A	B	C	S	M	H	D
	Stainless Steel		6	8	10	12	14	16	18	20 <sup>NS</sup>	22 <sup>NS</sup>	25 <sup>NS</sup>	± 0.08	± 0.08	Max.	± 0.08	Max.	Nom	Anvil Hole + 0.08	
SKC	61.5	61.5	6	8	10	12	14	16	18	20 <sup>NS</sup>	22 <sup>NS</sup>	25 <sup>NS</sup>	2.5	4.5	5.38	1.72	2.75	6.35	5.5	

(NS) Not Stocked. Available on special order.

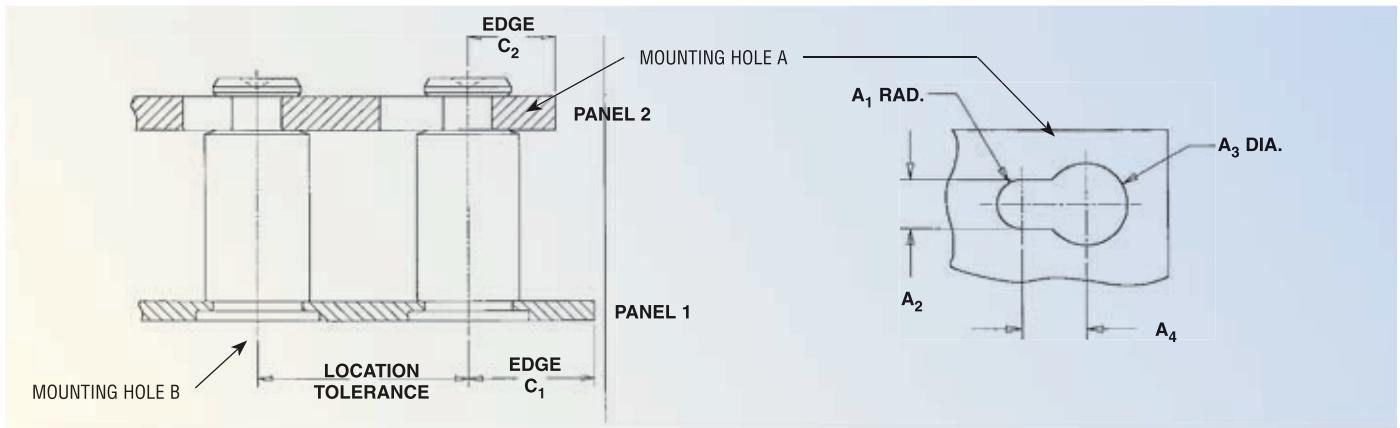

All dimensions are in inches.

UNIFIED	Type	PANEL 1					PANEL 2						
		Bottom Mounting Hole B + .003 - .000	Hardness Max.	Thickness Min.	Edge Distance C <sub>1</sub> Min.	Location Tolerance Max.	Top Mounting Hole A				Material	Thickness Range	Edge Distance C <sub>2</sub> Min.
							A <sub>1</sub> Nom.	A <sub>2</sub> ± .003	A <sub>3</sub> ± .003	A <sub>4</sub> Min.			
SKC		.213	HRB 70	.040	.260	± .005	.059	.118	.197	.148	PC Board or Metal	.057-.064	.160

All dimensions are in millimeters.

METRIC	Type	PANEL 1					PANEL 2						
		Bottom Mounting Hole B + 0.08	Hardness Max.	Thickness Min.	Edge Distance C <sub>1</sub> Min.	Location Tolerance Max.	Top Mounting Hole A				Material	Thickness Range	Edge Distance C <sub>2</sub> Min.
							A <sub>1</sub> Nom.	A <sub>2</sub> ± 0.08	A <sub>3</sub> ± 0.08	A <sub>4</sub> Min.			
SKC		5.4	HRB 70	1	6.6	± 0.13	1.5	3	5	3.75	PC Board or Metal	1.45-1.62	4.1

# INSTALLATION

1. Punch or drill properly sized mounting hole in Panel 1.
2. Place the barrel of the fastener through mounting hole and into anvil as shown in drawing to the right.
3. With the punch and anvil surfaces parallel, apply only enough squeezing force to embed the head flush with the panel.

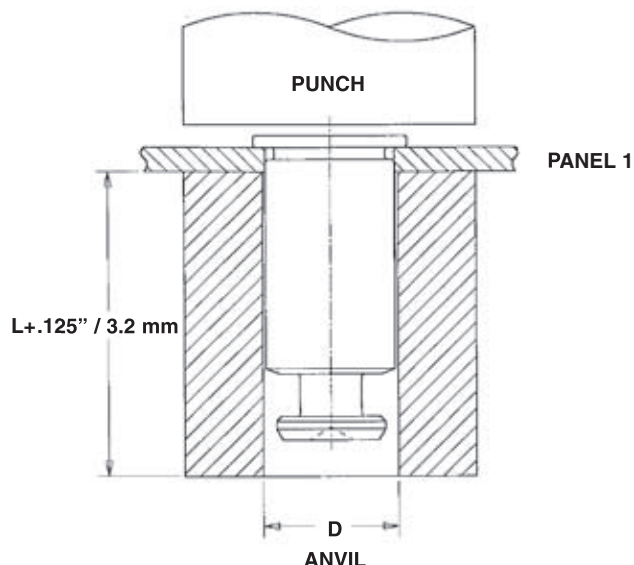

## PERFORMANCE DATA<sup>(1)</sup>

### Installation and Pushout

		.060" 5052-H34 Aluminum		.060" Cold-Rolled Steel	
UNIFIED	Body Size - Sheet Code	Installation (lbs.)	Pushout (lbs.)	Installation (lbs.)	Pushout (lbs.)
		6060	1600	250	3200

		1.52 mm 5052-H34 Aluminum		1.52 mm Cold-Rolled Steel	
METRIC	Body Size - Sheet Code	Installation (kN)	Pushout (N)	Installation (kN)	Pushout (N)
		61.5	7.1	1100	14.2

### Permissible Side-Loading

		.060" 5052-H34 Aluminum									.060" Cold-Rolled Steel								
		Length Codes									Length Codes								
UNIFIED	Body Size - Sheet Code	-6	-8	-10	-12	-14	-16	-20	-24	-32	-6	-8	-10	-12	-14	-16	-20	-24	-32
		Side-Load Force Max. (lbs.)									Side-Load Force Max. (lbs.)								
	6060	82	63	52	44	38	34	27	22	17	197	153	126	106	92	81	66	55	42

		1.52 mm 5052-H34 Aluminum										1.52 mm Cold-Rolled Steel									
		Length Codes										Length Codes									
METRIC	Body Size - Sheet Code	-6	-8	-10	-12	-14	-16	-18	-20	-22	-25	-6	-8	-10	-12	-14	-16	-18	-20	-22	-25
		Side-Load Force Max. (N)										Side-Load Force Max. (N)									
	61.5	296	228	184	156	136	116	104	96	88	76	696	540	440	372	320	280	252	228	208	184

(1) The installation and pushout values reported are averages when all installation specifications and procedures are followed. Variations in mounting hole size, panel material and installation procedure will affect this data. Performance testing of this product in your application is recommended. We will be happy to provide samples for this purpose.

RoHS compliance information can be found on our website.

Specifications subject to change without notice.  
Check our website for the most current version of this bulletin.

PennEngineering®



North America: Danboro, PA 18916 USA • E-mail: info@pemnet.com • Tel: +1-215-766-8853 • Fax: +1-215-766-0143 • 800-237-4736 (USA Only)  
 U.K. And Europe: Doncaster, England • E-mail: uk@pemnet.com Tel: +44 (0)1302 765700 • Fax: +44 (0)1302 367580  
 Asia/Pacific: Singapore • E-mail: singapore@pemnet.com • Tel: +65-6-745-0660 • Fax: +65-6-745-2400  
 Shanghai, China • E-mail: china@pemnet.com • Tel: +86-21-5868-3688 • Fax: +86-21-5868-3988

Visit our PEMNET™ Resource Center at [www.pemnet.com](http://www.pemnet.com)

CAGE-46384